

ELECTRON DIFFRACTION TUBE TEL 555

The Electron Diffraction Tube TEL 555* has been improved to give greater protection of the diffracting graphitised-carbon layer and to provide a wider range of voltage (see Nuffield Advanced Science : Physics Unit 10 "Waves, Particles and Atoms" p.52).

READ THESE NOTES BEFORE USING THE TUBE :

Connect e.h.t. negative to the 2mm diameter socket only. In the previous design, e.h.t. negative was connected to the heater; this must not be done otherwise the diffracting layer could be damaged.

Automatic Biassing

The construction of the gun has been modified to provide better control of the emitted electron current. This is effected by "automatically biassing" the cathode can that surrounds the cathode by arranging for the total emitted current to pass through a resistor connected between cathode and can in such a way that the latter is kept negative with respect to the cathode. Increase in current makes the can more negative so reducing the emitted current and, incidentally, improving the focussing. The cathode can is connected to the 2mm diameter socket in the base cap ; a free plug is supplied with each tube.

External Biassing

Further control of the cathode ray current can be achieved by connecting the \ominus ve terminal of the heater (which is connected internally to the cathode) and the 2mm diameter socket to an external 0-50V source. By increasing the negative bias at the latter terminal, improved focussing allows the diffraction pattern to be seen at lower e.h.t.

Negligible current is required and the beam can be "cut off" at about \sim 40V.

Operational Parameters

Anode Current - 0.2 ± 0.05 mA for $V_A = 5$ kV.

Heater Voltage - 6.0 ± 1 volt a.c.

Because the anode current is low, higher voltages can be achieved thus permitting a wider range of experimental points giving greater precision.

As a safeguard, a meter should be included in the anode circuit at all times

Construction

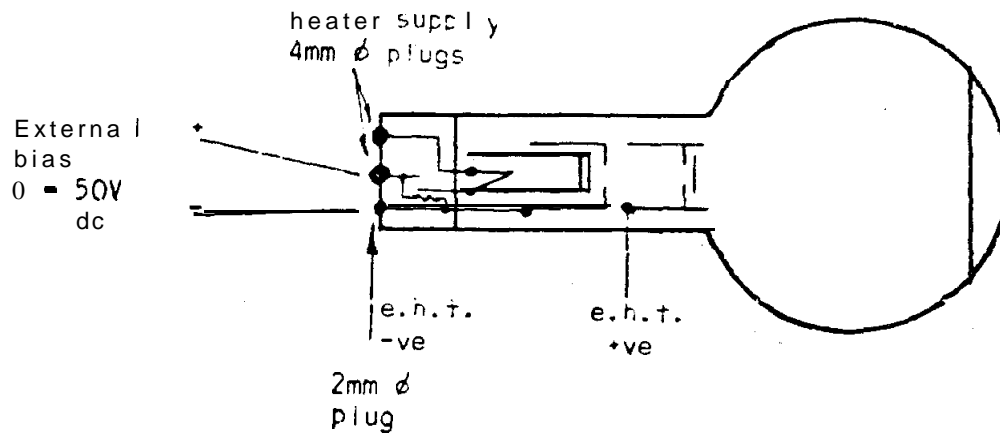

Every care has been taken in selecting the biasing resistor, R, individually, but the nickel grid supporting the diffracting layer of carbon in the exit-anode of the gun should be inspected from time to time to check that it is not overheating. If so, the heater voltage should be reduced slightly. In general, the operation should be satisfactory and independent of the heater voltage over the range given above.

ELECTRON DIFFRACTION TUBE, TEL 555 & OPTICAL ANALOCUE, TEL 555a.

The Optical Analogue, TEL 555a, comprises an aluminium disc mounted on a hollow shaft which rotates in a ball-race in a plastics holder. The holder can be mounted in the back of the jaws of the Universal Stand. Located in the bore of the shaft is a rectilinear, 500-mesh grid. Supplied with the Analogue are two colour filters and an aperture for use with a 35 mm projector.

The Electron Diffraction Tube, TEL 555, comprises a 'gun' which emits a converging narrow beam of cathode rays within an evacuated clear glass bulb on the surface of which is deposited a luminescent screen. The cathode rays pass through a thin layer of graphiticised carbon supported on a fine mesh grid in the exit aperture of the 'gun' and are diffracted into two rings corresponding to separations of the carbon atoms of 1.23 and 2.13 angstroms. The source of the cathode rays is an indirectly-heated oxide-coated cathode, the heater of which is connected to 4 mm sockets in a plastics cap at the end of the neck; connection to the anode of the 'gun' is by a 4 mm plug mounted on the side of the neck.

The tube can be mounted on the Universal Stand, TEL 501. A rotatable magnet is supplied which can be clipped onto the neck of the tube to provide a means of deflecting the cathode rays within the gun to give the best diffraction pattern.

Specific&ion :

Filament voltage	Normal 6.3V a.c./d.c. ; max. 9.0V a.c./d.c.
Anode voltage	3,500 5,000V d.c.
Anode current	.2 - .4 mA.

Recommended Experiments :

Experiments with the Maltese Cross Tube. TEL 523, demonstrate that cathode rays exhibit some properties similar to those of light and other properties consistent with electrically charged particles. It was suggested by de Broglie in 1926 that particles could have wave properties where the wavelength, λ , is inversely proportional to momentum, $A = \frac{h}{mv}$,
 $h =$ Planck's constant

The Teltron Series 'A' Experiments confirm that electrons obey the laws of motion and lead to a measure of the specific charge e/m . The Milikan experiment establishes the discrete nature of the electron, gives a measure of charge e and thereby an evaluation of its mass m . Sufficient information is thus available to test de Broglie's hypothesis.

The possibility of diffraction :

A calculation using de Broglie's equation shows that electrons accelerated through a p.d. of 4 kV have a wavelength of about .2 angstroms. Interference and diffraction effects, as studied in physical optics, demonstrate the existence of waves. For a simple ruled grating, the condition for diffraction is $\lambda = d \sin \theta$ or for small angles $\theta = \frac{\lambda}{d}$, d being the spacing of the grating. The best man-made gratings are ruled at 40,000 lines/inch and with a wavelength of 0.2 A, θ will be one second of arc or only $\frac{1}{2}$ mm at 10 m from the grating. If electron diffraction is to be observed in a Teltron tube of 13.5 cm diameter, the spacing between 'rulings' to produce the first order at 1.35 cms from zero, (i.e. $\sin \theta = 0.1$), must be 2.0 A.

It was von Laue who suggested, in connection with x-ray studies, that if fine gratings could not be made by man because of the structure of matter, then perhaps the structure of matter itself could be used as a grating. Bragg, using the cubic system of NaCl, first calculated the interatomic spacings and showed them to be of the right order for x-rays.

A similar calculation using carbon assuming that its atoms form a simple cubic system, can be made, viz : 12 gms of carbon contain 6×10^{23} atoms (Avogadro's No.) ; since the density of carbon is about 2 gms/cm³, 1 cm³ contains 10^{23} atoms so that adjacent carbon atoms will be about $\sqrt[3]{10}$ or a little over 2 A apart. In other words, carbon should provide a grating of the correct spacing for the experiment. The nature of the effect to be observed however is not evident from these calculations.

Experiment 22 (Series 'A') Optical analogue of electron diffraction.

The nature of the diffraction effect from the carbon "grating" can be investigated optically. The rectilinear grid corresponds to a section through the assumed cubic arrangement of carbon atoms. Set up the optical analogue as in Figure 1, and focus the spot produced by the slide onto a screen and then interpose the analogue. Alternatively, view a point source of white light directly through the analogue.

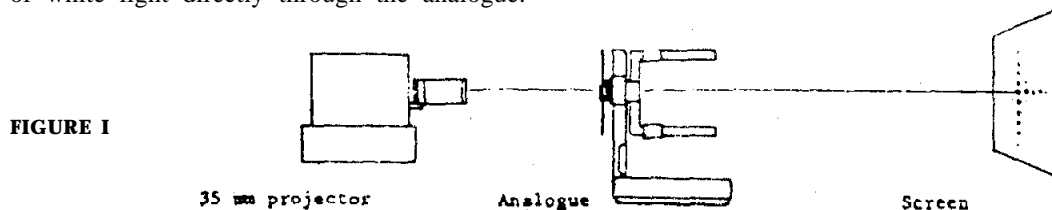

A coloured "cross" pattern is observed indicating that the grid is acting as two line gratings perpendicular to each other. This symmetrical pattern would therefore be observed if the carbon atoms are uniformly arranged. If, however, a more or less random arrangement of equally spaced atoms exists, then a different pattern should be observed. Such a random arrangement can be simulated by rotating the grid rapidly, when a ring pattern is observed. The dependence of the diffraction pattern on wavelength can be tested by viewing in red and green light, when it is seen that the ring diameter decreases significantly with decrease in wavelength (red to green).

Experiment 23 (Series 'A') Demonstration of Electron Diffraction.

Connect the tube, TEL 555, into the circuit shown in Figure 2, and switch on the heater supply and allow about one minute for it to stabilise. Adjust the E.H.T. setting to 4 kV and switch on.

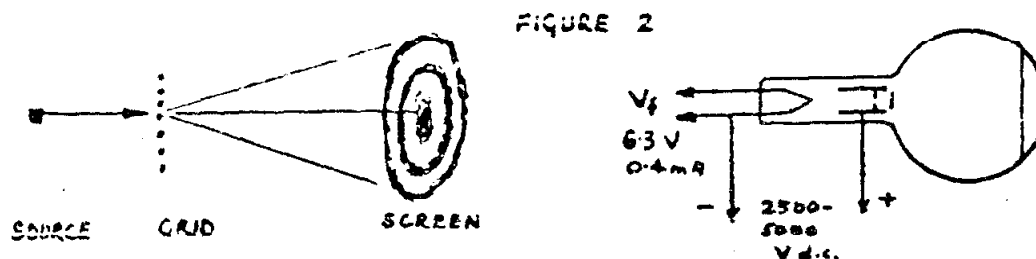

Two prominent rings about a central spot are observed, the diameter of the inner ring being in fair agreement with the calculated value.

Variation of the anode voltage causes a change in ring diameter, a decrease in voltage resulting in an increase in diameter. This is in accord with de Broglie's suggestion that wavelength increases with decrease in momentum.

Although conclusive evidence of the particulate nature of the electron has been previously obtained, this demonstration which closely resembles the optical one reveals the dual nature of the electron.

Experiment 24 (Series 'A') Variation of Electron Wavelength with Anode Voltage.

Use the circuit in Figure 2 and measure (in a darkened room) the diameter of the rings with different anode voltages V_a and tabulate results.

An expression for the momentum of electrons can be derived from the 'gun' equation 14.3, $eV_a = \frac{1}{2} mv^2$ which substituted in de Broglie's equation gives

$$\lambda = \frac{h}{\sqrt{2emV_a}} = \frac{\sqrt{150}}{V_a} \text{ angstroms} \quad \dots\dots 24.1$$

If the beam travels a distance L after diffraction through a small angle θ , the diameter of the resulting ring is : $D = 2 L\theta$. . . 24.2

From the diffraction equation, $\lambda = d\theta$ for small angles.

Substituting in equation 24.2 it is seen that the ring diameter is proportional to wavelength

$$\lambda = \frac{Dd}{2L} \quad \dots\dots 24.3$$

Finally, equating equations 24.1 and 24.3 and rearranging, the ring diameter is found to be inversely proportional to the square root of the anode voltage

$$D = \frac{2L}{d} = \frac{\sqrt{150}}{V_a} \quad \dots\dots 24.4$$

To verify the theory, plot a graph of ring diameter $V_a^{-\frac{1}{2}}$,

- (a) the straight lines obtained for the two circles verify the theory and substantiate de Broglie's hypothesis.
- (b) from the gradients, the spacing, d , for the two sets of diffracting planes can be calculated.
- (c) the ratio of the spacings are found to be $\sqrt{3} : 1$ suggesting that the arrangement of carbon atoms is more likely to be hexagonal than cubic.

Typical Results :

V_a kV	2.5	4.0	6.0	6.9
D mm Outer ring	50	43	39	36
D mm Inner ring	29	25	24	21

$L = 13.5 \text{ cm}$
 $d_{inner} = 1.20 \text{ A}$
 $(d_{11} = 1.23 \text{ A})$
 $d_{outer} = 2.06 \text{ A}$
 $(d_{10} = 2.13 \text{ A})$

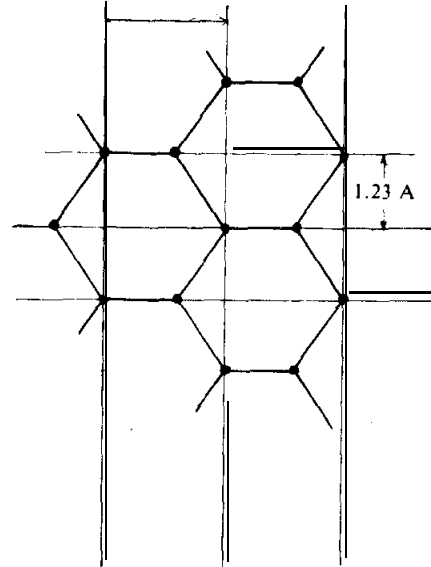
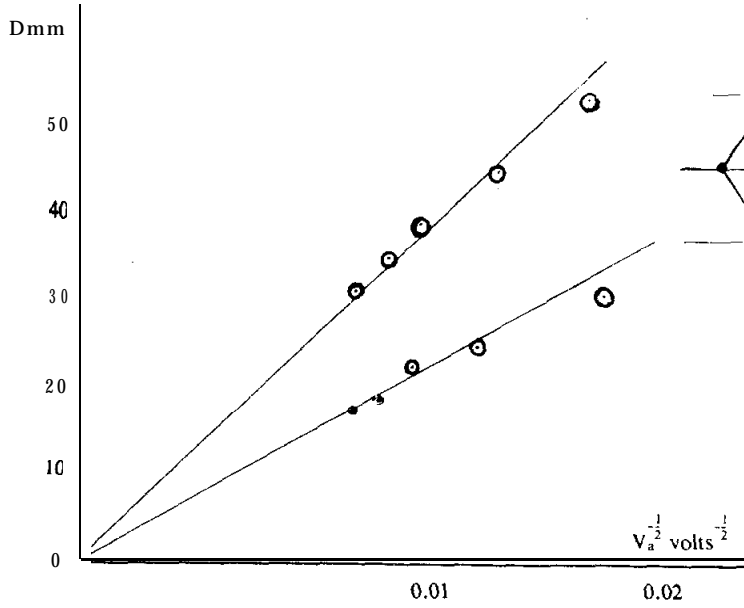

HELMHOLTZ COILS. TEL. 502

These magnetising coils, supplied in pairs, when mounted on the Universal Stand TEL 501 automatically present the Helmholtz assembly as in Figure 1.

Each coil has 320 turns of 22 swg enamelled copper wire wound on a plastics former of 13.6 cm mean diameter. The bobbin is mounted on a stainless steel support rod which is terminated by an insulating button. The plastic fingergrip sleeve sliding on the rod locates the whole assembly in the tapered hole in the base of the Universal Stand as shown in Figure 2.

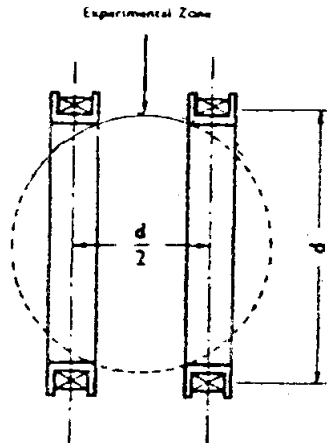

FIGURE 1 THE HELMHOLTZ GEOMETRY

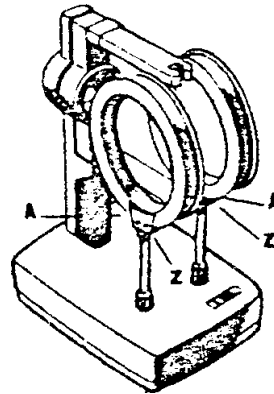

FIGURE 2 COILS IN POSITION

The start of each coil is connected to the 4 mm socket (A) on the side of the bobbin, and the finish to the 4 mm socket (Z).

For a normal series - connected Helmholtz arrangement connect the power supply to sockets A, with sockets Z interconnected.

CALCULATION OF MAGNETIC FIELD.

The Helmholtz arrangement presents a substantially uniform field in the central region of the coils calculated as follows :-

$$\text{Field } H = \frac{8n}{5\sqrt{5}} \cdot \frac{I}{r} \text{ amp/metre}$$

where n = no. of turns (320), r = mean radius (0.068 m), I = current in amps.

$$\text{Flux density } B = \frac{32\pi n}{5\sqrt{5}} \cdot \frac{I}{r} \cdot 10^{-7} \text{ weber/sq. metre}$$

To obtain a continuous field of about 30 amp/m, an input of 12V and about 1.0 A should not be exceeded. The maximum short-duration field of 45 amp/m from an input of 18V and 1.5A should not be applied for more than 10 minutes.

๔
ชื่อ

นามสกุล

รหัส

กระดาษบันทึกผลการทดลอง

A large rectangular grid consisting of 20 columns and 25 rows, intended for recording experimental data. The grid is empty and occupies most of the page area.

ชื่อ

นามสกุล

รหัส

กระดาษบันทึกผลการทดลอง .

ชื่อ

นามสกุล

รหัส

กระดาษบันทึกผลการทดลอง

ชื่อ

นามสกุล

รหัส

กระดาษบันทึกผลการทดลอง
